

PLANTA BAJA

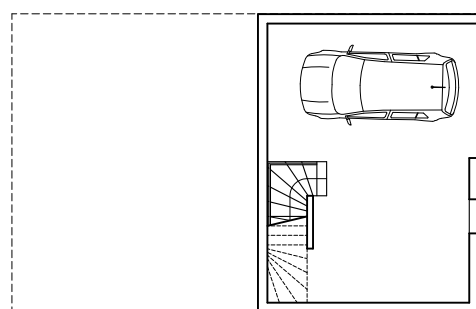

PLANTA SÓTANO

**cuadro de superficies**

DESCRIPCIÓN	SUP. ÚTIL	SUP. CONST.
<b>VIVIENDA</b>	<b>80.69 m<sup>2</sup></b>	<b>97.61 m<sup>2</sup></b>
PL. BAJA	80.69 m <sup>2</sup>	97.61 m <sup>2</sup>
escalera	2.15 m <sup>2</sup>	
estar-comedor	27.21 m <sup>2</sup>	
cocina	13.24 m <sup>2</sup>	
lavanderia-tendedero	4.78 m <sup>2</sup>	
distribuidor	3.81 m <sup>2</sup>	
baño	5.01 m <sup>2</sup>	
dormitorio 1	13.27 m <sup>2</sup>	
dormitorio 2	11.21 m <sup>2</sup>	
<b>P. SÓTANO</b>	<b>37.88 m<sup>2</sup></b>	<b>46.02 m<sup>2</sup></b>
garaje	35.73 m <sup>2</sup>	
escalera	2.15 m <sup>2</sup>	
<b>TOTAL</b>	<b>118.57 m<sup>2</sup></b>	<b>143.63 m<sup>2</sup></b>
<b>TOTAL SUP. ÚTIL</b>	<b>118.57 m<sup>2</sup></b>	
<b>TOTAL SUP. CONSTRUIDA</b>		<b>143.63 m<sup>2</sup></b>
<b>SUP. OCUPADA</b>		<b>97.61 m<sup>2</sup></b>

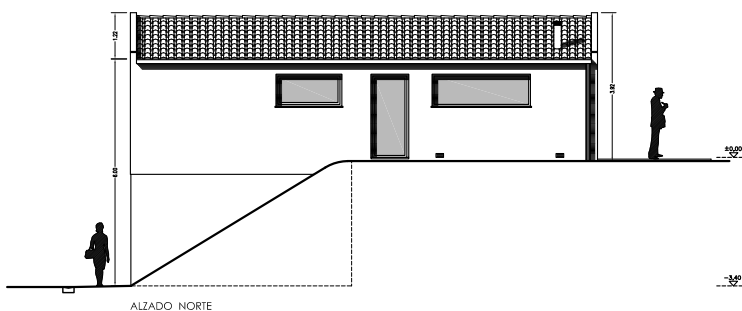

ALZADO NORTE

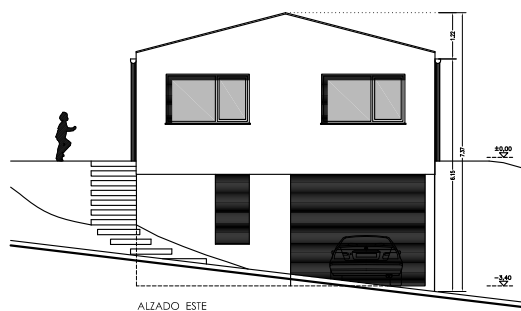

ALZADO ESTE

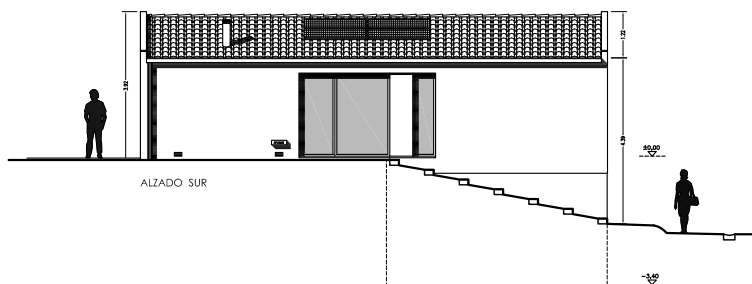

ALZADO SUR

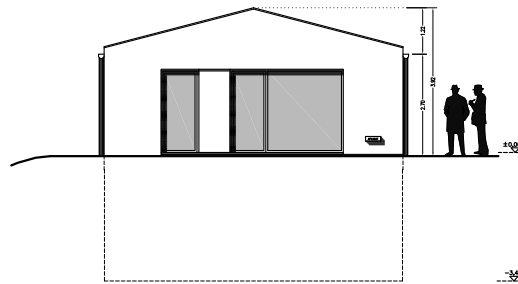

ALZADO OESTE